



HYBRID INVERTER

CESS-HY-25/30/36/40/50K

CESS-HY-40/50K-P









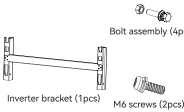
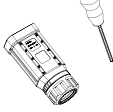

Quick Installation Guide

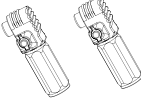
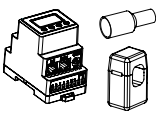
ENGLISH VERSION

1 Installation

A Check Packing List

 <p>Inverter 1pcs</p>	 <p>Bolt assembly (4pcs) Inverter bracket (1pcs) M6 screws (2pcs)</p>	 <p>AC connector set (3 pcs)</p>	 <p>PV terminal CESS-HY-25-50K 8 pairs / CESS-HY-40-50K-P 6 pairs</p>
 <p>Battery terminal (1 pairs)</p>	 <p>Meter with 3 CTs 1pcs</p>	 <p>COM2 connector set (1pcs)</p>	 <p>COM3 connector set (1pcs)</p>
 <p>Monitoring device 1pcs</p>	 <p>10m meter communication cable 1pcs 3m battery communication cable 1pcs</p>	 <p>PE terminal 1pcs</p>	 <p>Quick Installation Guide User guide</p>

B Installation Location

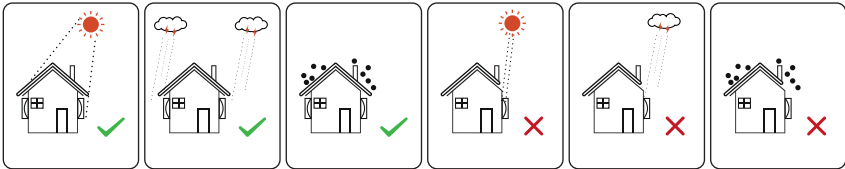

C Installation Space

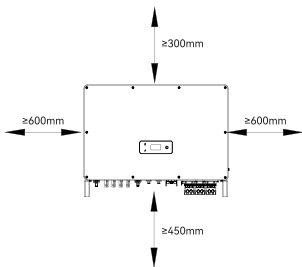

D Installation Angle

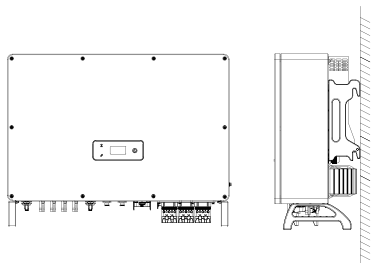

E Mark the Position and Drill Holes

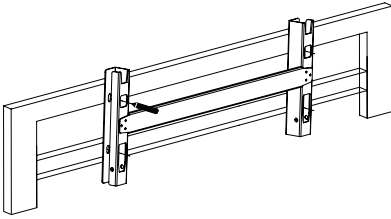

F Fix Wall Bracket

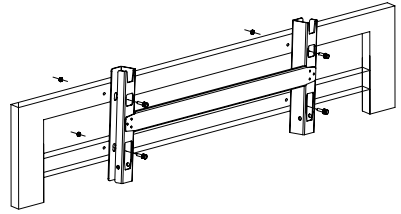

G Mounting Inverter

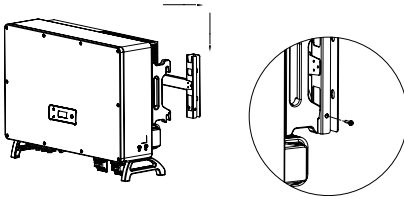

H Grounding Terminal Connection

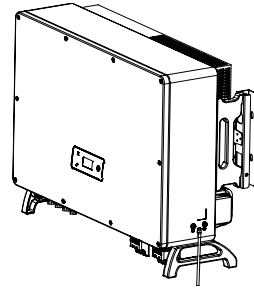

2 Electrical Connection

A Cable Requirements

Cable types	Cable requirements	
	Outside diameter	Conductor core section
AC cable	20.0-30.0 mm	10.0-25.0mm ² (Flexible cable)
		10.0-35.0mm ² (Hard cable)
PV cable	5.9-8.8 mm	4.0 mm ²
Battery power cable	9.8±0.2 mm	25.0 mm ²

Please use the cable specified in the above table. If the conductor core of the cable is too small, which may cause poor contact between the terminal and cable.

B

Electrical Wiring Diagram

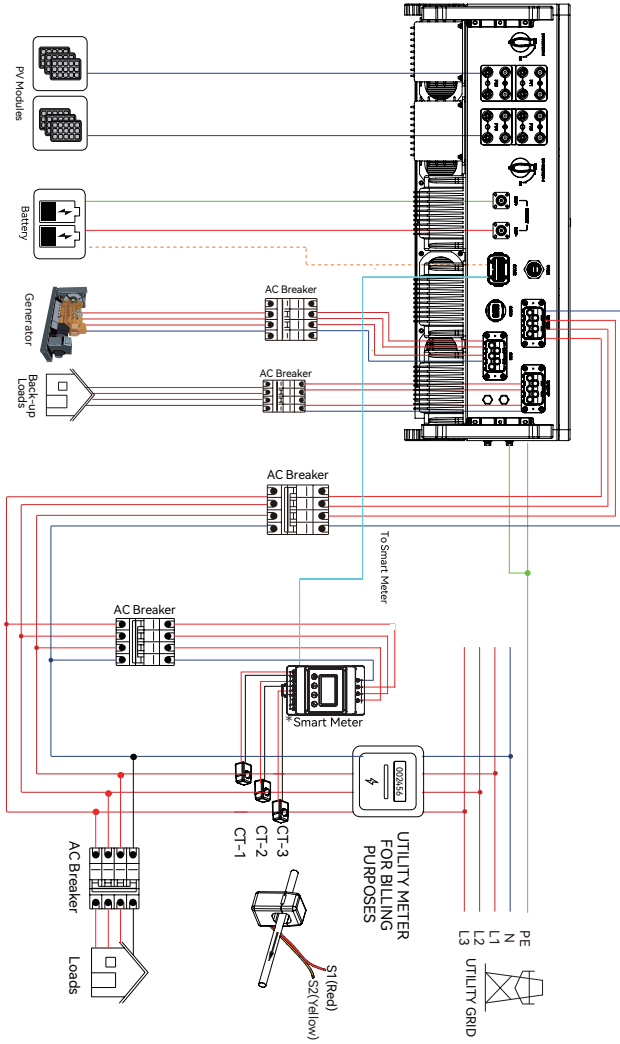

C AC Connection

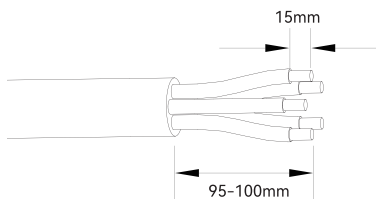

①

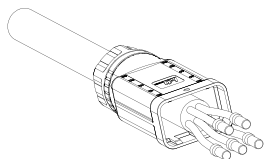

②

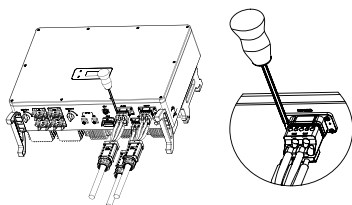

③

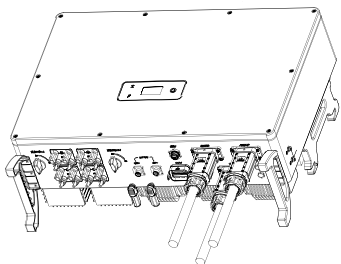

④

D Meter and CT Connection

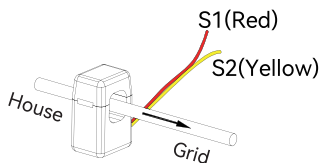
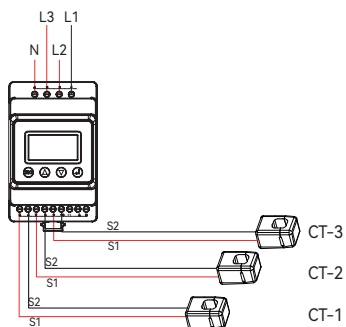
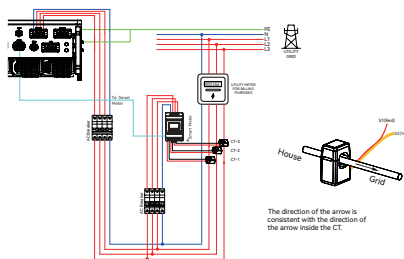

Meter Terminals Definition

No.	Definition	Function
	SM	
1	L1	L1/L2/L3/N connect to grid to detect power grid voltage
2	L2	
3	L3	
4	N	
5	L1-S1	To detect the CT current and direction
6	L1-S2	
7	L2-S1	
8	L2-S2	
9	L3-S1	
10	L3-S2	
11	PE	Ground connection
RS485	Reserve	Communicate with hybrid inverter
	RS485-2	
ANT	Reserve	Communicate with hybrid inverter
LAN	Reserve	
Type-C	Type-C	Specified Debug Interface. Do not use it by non-professionals

E Communication Connection

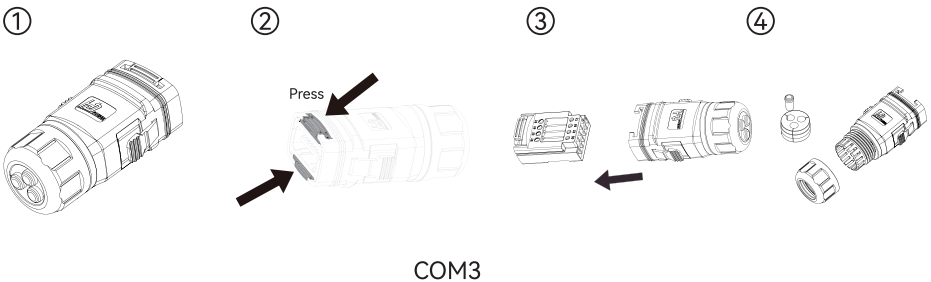
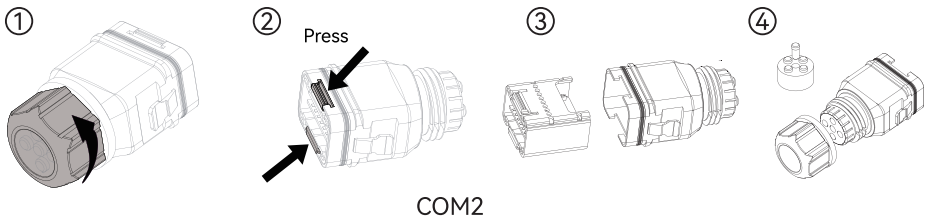

Pin	Definition	Function
METER (RJ45-1)	RS 485	Communicate with Meter
BMS (RJ45-1)	CAN	Communicate with BMS
1	COM	DO-1 (Multifunction Relay)
2	NO (Normally Open)	
3-4	/	Reserved
5	DRM4/8	DRED For Australia and New Zealand RCR For Germany and some other European countries
6	DRM3/7	
7	DRM2/6	
8	DRM1/5	
15	COM D/0	
16	REF D/0	
9-10	/	Reserved
11	Emergency stop +	Emergency stop
12	Emergency stop -	
13	485 B1	EMS
14	485 A1	
17	CANL_P	CAN for parallel connection of inverters
18	CANH_P	
19-20	/	Reserved

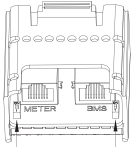

Terminating resistor for CANL(Parallel)
Terminating resistor for CANH(Serial)

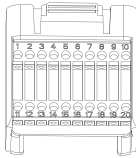

COM2

Pin	Definition	Function
1-6	/	Reserved
7	COM	DO-2 (Multifunction Relay)
8	NO	
9-10	/	Reserved
11	COM	DO-3 (Multifunction Relay)
12	NC	
13-16	/	Reserved
17	4-20mA_OUT	4-20mA analog output
18	GND	
19	GND	0-10V analog output
20	0-10V_OUT	

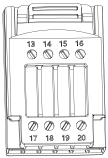
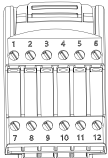

COM3

Connect the Meter and BMS Communication Cables

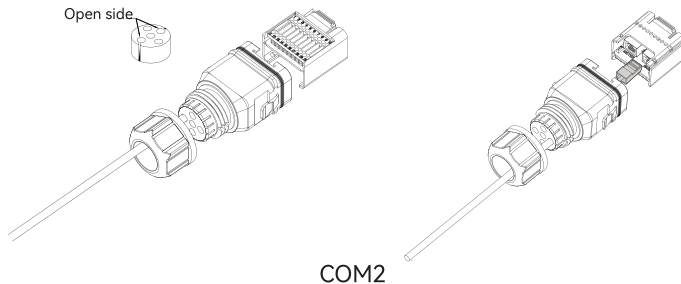

Connect Other Cables

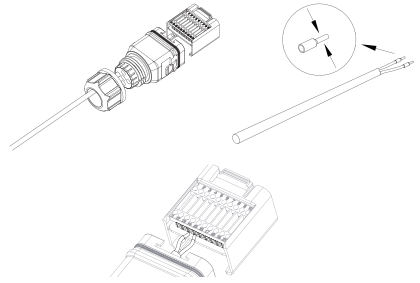
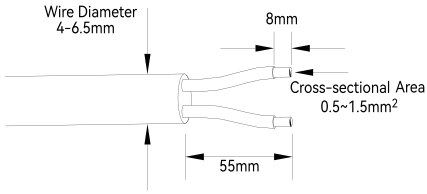

COM2

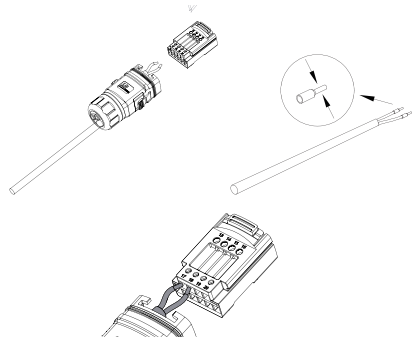
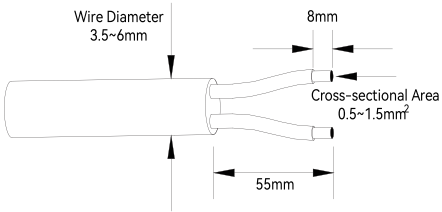

COM3

Installing the COM Connector

①

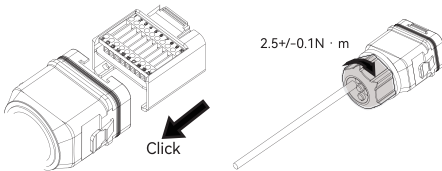

COM2

③

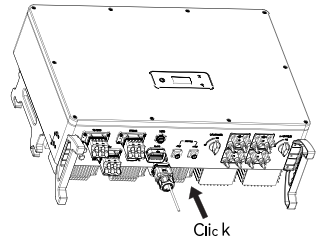

②

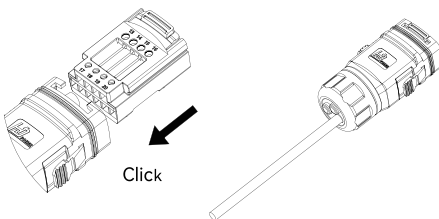

COM3

F PV String Connection

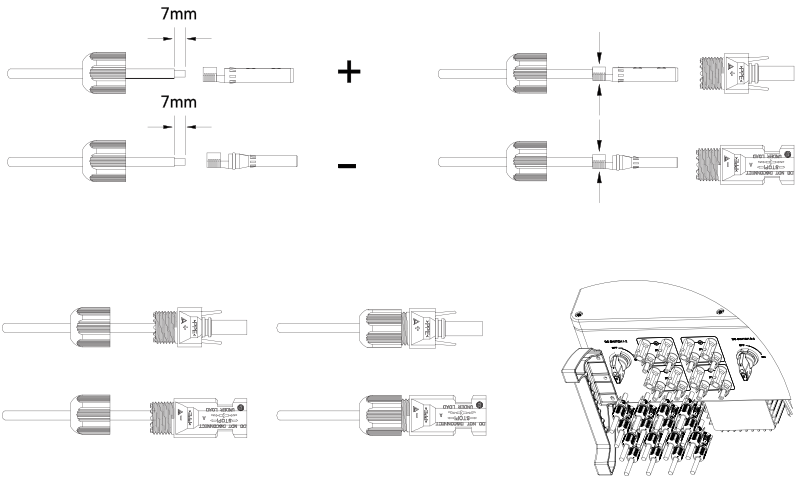

PV Max. Input voltage is 850V , otherwise inverter will be waiting.

G Power Cable of the Battery Connection

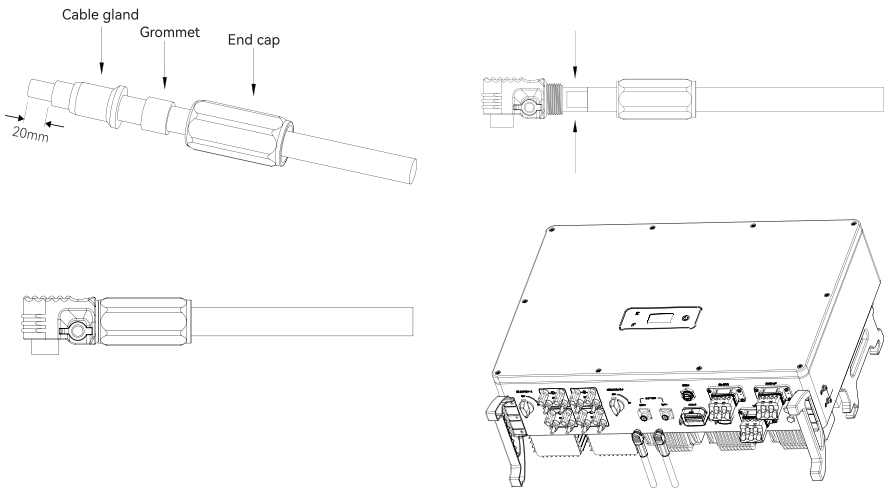

H Monitoring Device Installation

INV-Logger A210(Monitoring device) supports both WiFi and LAN connection.

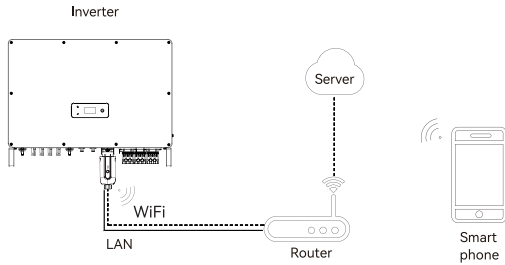

If you select WiFi connection, the operation method is described in "4.APP Guide".

If you select LAN connection, see the following contents and steps.

Tips: When WiFi and LAN are connected at the same time, the communication method will be prioritized to LAN.

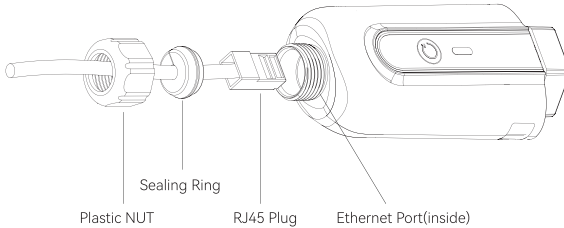

Figure 2-1

Step1: Remove the "Plastic Nut" and "Sealing Ring" in turn.

Step2: Pass the network cable plug through the "Plastic Nut" and "Sealing Ring" (with opening) in the direction as shown in the figure 2-1.

Step3: Fully embed the "Sealing Ring" into the "Plastic Nut".

Step4: Connect the "RJ45 Plug" to the Ethernet Port(inside) and tighten the "Plastic Nut" for better waterproofing.

Step5: Connect the "INV-Logger A210" to the "COM1" as shown in the figure 2-2.

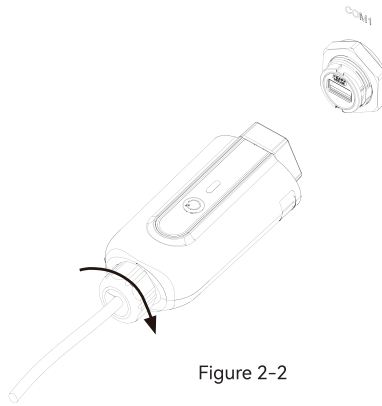
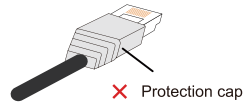
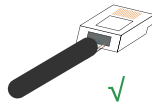

Figure 2-2

Due to limited space, only RJ45 plug without protective cap can be used.



The network cable is required to be circular or oval, and the diameter of the network cable needs to be greater more than 5.5mm and less than 6.5mm in order to be properly sealed.

If you want to remove the network cable, unscrew the plastic case and seal-ing ring, and use a one-piece screwdriver to press in the way shown below, then pull out the cable.

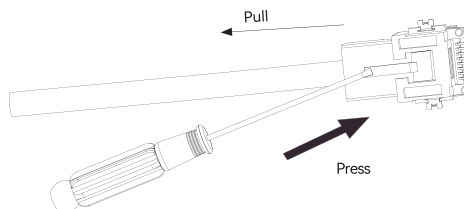
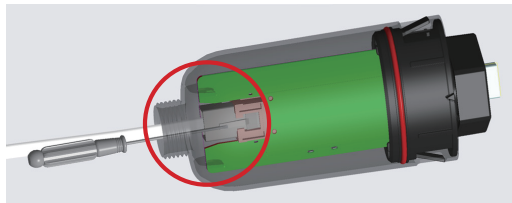

3 Commissioning

A Inspection Before Commissioning

Check the following items before starting the inverter:

- ① All equipment has been reliably installed.
- ② DC switch(es) and AC circuit breaker are in the "OFF" position.
- ③ The ground cable is properly and reliably connected.
- ④ The AC cable is properly and reliably connected.
- ⑤ The DC cable is properly and reliably connected.
- ⑥ The communication cable is properly and reliably connected.
- ⑦ The vacant terminals are sealed.
- ⑧ No foreign items, such as tools, are left on the top of the machine or in the junction box (if there is).
- ⑨ The AC circuit breaker is selected in accordance with the requirements of this manual and local standards.
- ⑩ All warning signs & labels are intact and legible.

B Commissioning Procedure

If all of the items mentioned above meet the requirements, proceed as follows to start up the inverter for the first time.

- ① Turn on the AC breaker.
- ② Turn on the lithium battery breaker. Power on the battery pack manually if a battery is equipped.
- ③ Turn the DC switch, the DC switch may be integrated in the inverter or installed by the customer.
- ④ If the irradiation and grid conditions meet requirements, the inverter will normally operate. The connection time for inverter to grid may take few minutes or even to more according to different country code chosen in the initial settings and the real site grid condition.
- ⑤ Observe the LED indicator to ensure that the inverter operates normally.

4 APP Guide

A App Download

You can scan the QR code or visit the website to download the HanchuEss App: <https://iess.hanchuess.com>.

You can also download the HanchuEss App from the App store or Google play.



Android APP



IOS APP



B Device binding

①. Registering and login

• If you have already registered, you can log in directly . Then you can turn to "② Bind devices".
If you don't have an account yet, tap "**Sign up**" to register as shown in Fig. 1.

• In order to provide you with the basic functionality of our products / services, you are required to authorise your consent to the "**Privacy Policy**" and "**Terms & Conditions**". We promise to keep users' information strictly confidential and will not disclose users' private information to outside parties unless authorised by the user or required by law.

• Fill in the account information

After filling in the information for registration, tap "**Get Verification Code**" as shown in Fig. 2.

We will send the verification code to your email.Fill in the code, and click on "**Confirm**" to log in, as shown in Fig. 3.

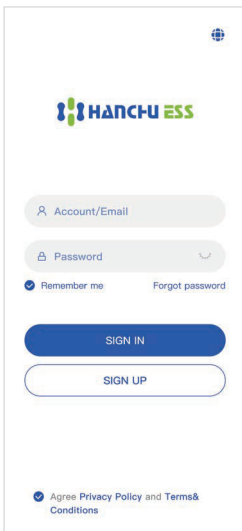

Fig. 1

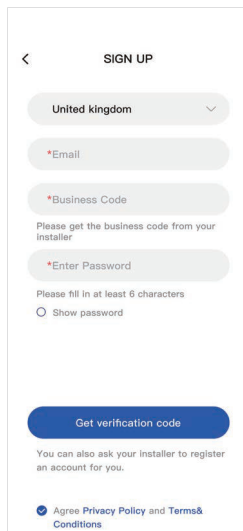

Fig. 2

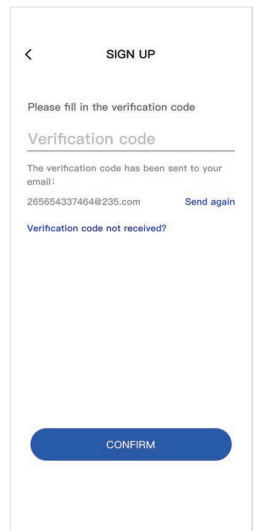

Fig. 3

②. Bind devices

You can jump to the relevant section referring to what you want to do:

- **Now you have a station, but need to setting the network for devices or add new devices to your station?**

- Please tap the "Add Device" button , as shown in Fig. 4. Then you can directly turn to **b.Network configuration**.

- Now you don't have a station yet?

- Tap "**Add station**" on the page, as shown in Fig. 5.

a. Fill in the new station information

You will need to fill in some information for the station, as shown in Fig. 6.

- Address (optional): Your detailed address, we will only use it for after-sales service.

- Electricity price setting (optional): After filled, you will be able to view the income and expenditure of your devices.

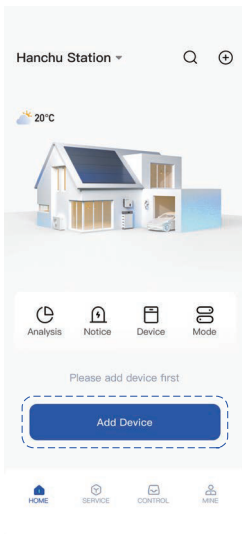

Fig. 4

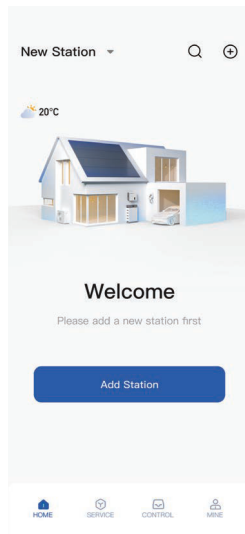

Fig. 5

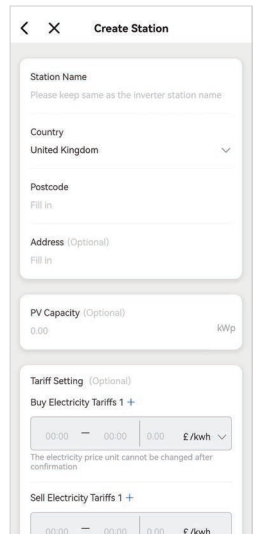

Fig. 6

b. Network configuration

Select the home Wi-Fi network you want to connect to (not 5GWiFi) and enter your WiFi password, as shown in Fig. 7.

c. Bluetooth search

Turn on your phone's Bluetooth, then select the devices you want to bind.

Tap "**Add**" to add the devices to your station, as shown in Fig. 8.

The SN on this page is the same as the SN on the logger.

! Tips: Please be sure to turn on the Bluetooth of the mobile phone, otherwise the binding function will not be available.

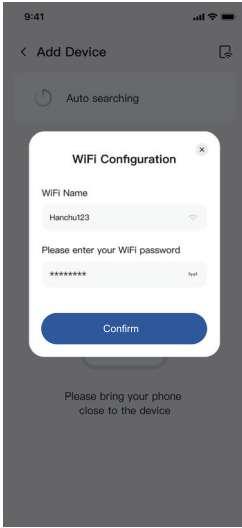

Fig. 7

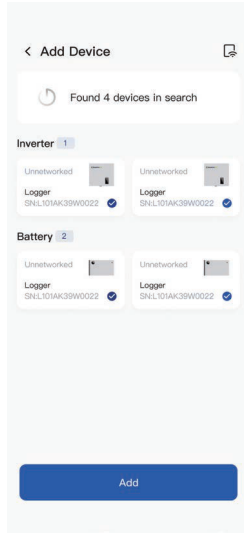

Fig. 8

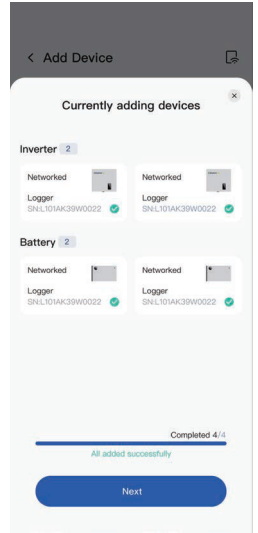

Fig. 9

d. Binding completed

After the devices are connected to the network and bound successfully, you will see the page shown in Fig. 9.

Please tap "**Next**".

e. Choose the inverter:

Choose one inverter to Setting.

f. Local Setting:

Then enter the local Setting page, as shown in Fig. 10. Click "**Complete**" to complete the Setting.

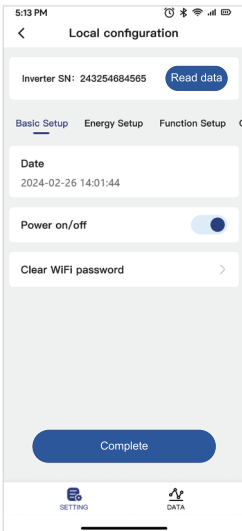

Fig. 10

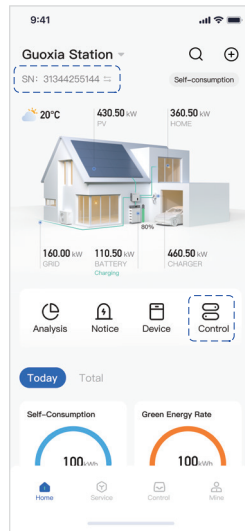

Fig. 11

! Tips:

- If you want to set more inverter configuration items, please contact your installer.
- If you want to set up the inverter remotely, enter the "Home" page, select the device you want to control, and click "Control" to operate the device remotely. As the following fig. 11

Congratulations! You have done the basic setting. Now you can view your device data on APP. You can also view your device data by logging into <https://iess.hanchuess.com>, the website login password is the same as the APP account password.

C Account and service information

Tap "**PERSONAL**" to view account information and app settings.

- Have any device malfunction or have technical problems?

Tap "**After Sales**", and you will see how to contact the service.

- Have any questions or suggestions about the APP?

You can leave us a message in the "**Suggestions feedback**" or contact us at service@hanchuess.com. We will deal with it for you as soon as we know.

- How do I view the device manual in the app?

Click "Data Center" on the "SERVICE" page to view the corresponding device information.

5 Indicator

A Inverter

Indicator	Status		Description
Power and Alarm Indicator	Off		No power.
	Green	Quick flashing	Inverter entered self-test status.
		Slow flashing	Inverter entered waiting status.
		Breathe flashing	Inverter works normal.
	Orange	Breathe flashing	Low battery warning, the battery power is about to reach the SOC protection value.
	Red	Always on	An alarm or fault is detected, view the fault info on the display.
Grid Indicator	Off		Grid lost.
	Slow flashing		Inverter detected grid but not running in on-grid mode.
	Always on		Inverter works in on-grid mode.
Communication Indicator	Green	Always on	The inverter communication is running normally.
	Green	Flashing	The inverter communicates with EMS or Master inverter through RS485 or CAN.
	Orange	Always on	The inverter isn't communicating with smart meter.
	Red	Always on	The inverter isn't communicating with the BMS.

B Monitoring Device

Indicator Status	Description
Off	Connection abnormal
Always On	The monitoring device is normal working.
Slow flashing	The monitoring device is not connected to the router.
Quick flashing	The monitoring device is connected to the router but not connected to the server.

Button	Description
Press 1 second	Reset device, the indicator goes off for 2 seconds, then flashes normally.
Press 5 second	Restore factory default settings, the indicator goes off for 2 seconds, then flashes once every 2 seconds, until the factory restore is completed.



www.hanchuess.com



M11-00012-01-AE