

Quick Installation Guide

HESS-HY-S-3.0K
 HESS-HY-S-3.68K
 HESS-HY-S-4.0K
 HESS-HY-S-5.0K
 HESS-HY-S-6.0K



English

I. Safety Instruction

1. The contents of this document will be updated irregularly for product version upgrade or other reasons. Unless otherwise specified, this document only works as guide. All statements, information and suggestions in this document do not constitute any guarantee.
2. This product can only be installed, commissioned, operated and maintained by technicians who have carefully read and fully understood the user manual.
3. This product must only be connected with PV modules of protection class II (in accordance with IEC 61730, application class A). PV modules with a high capacitance to ground must only be used if their capacity does not exceed 1.5μF. Do not connect any sources of energy other than PV modules to the product.
4. The product must only be operated in connection with an intrinsically safe lithium-ion battery approved by Hanchu ESS. The battery must comply with the locally applicable standards and directives and must be intrinsically safe.
5. The communication interface of the battery used must be compatible with the product. The entire battery voltage range must be completely within the permissible input voltage range of the product. The maximum permissible DC input voltage of the product must not be exceeded.
6. The PV modules generate dangerous high DC voltage which is present in the DC cable conductors and live components. The DC cables connected to a battery may be live. Touching live DC cable conductors and live components can result in lethal injuries due to electric shock.
7. All components must remain within their permitted operating ranges at all times.

II. Mounting environment

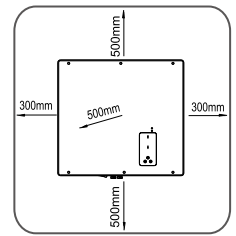
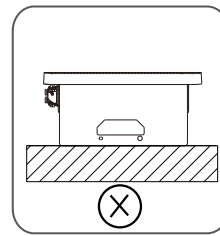
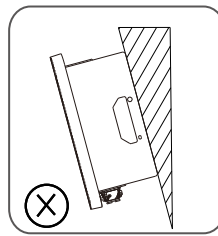
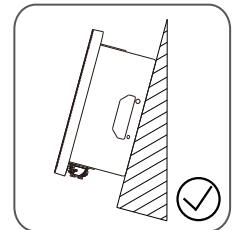
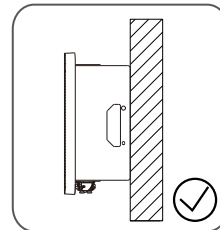
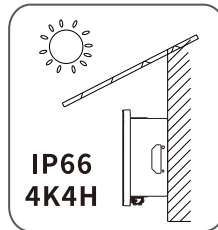

III. Scope of delivery

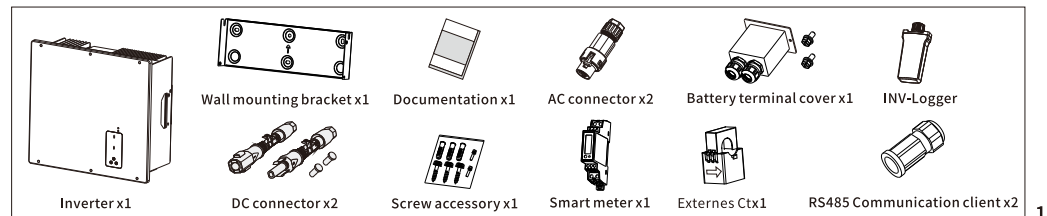

IV. Inverter's mounting

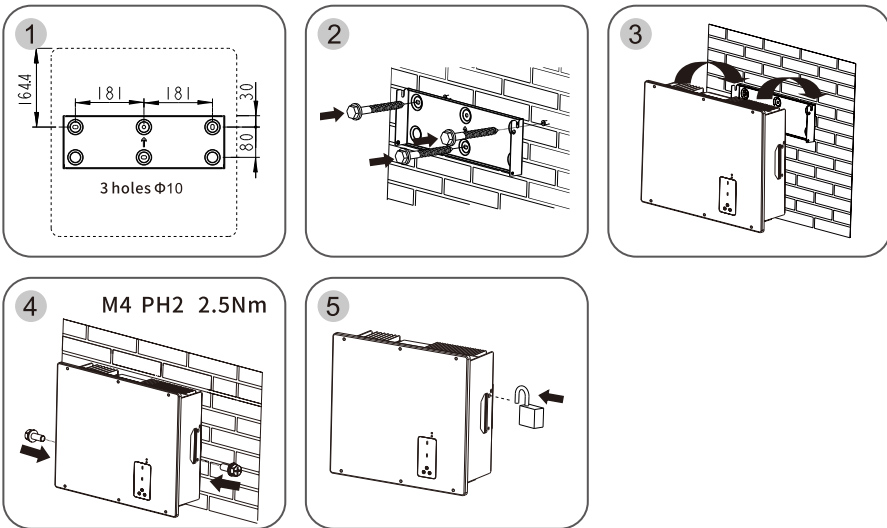

VI. Battery connection

- The lithium battery (pack) capacity should be 50Ah or larger.
- Lead acid batteries are not allowed.
- The battery type must be approved by Hanchu ESS.

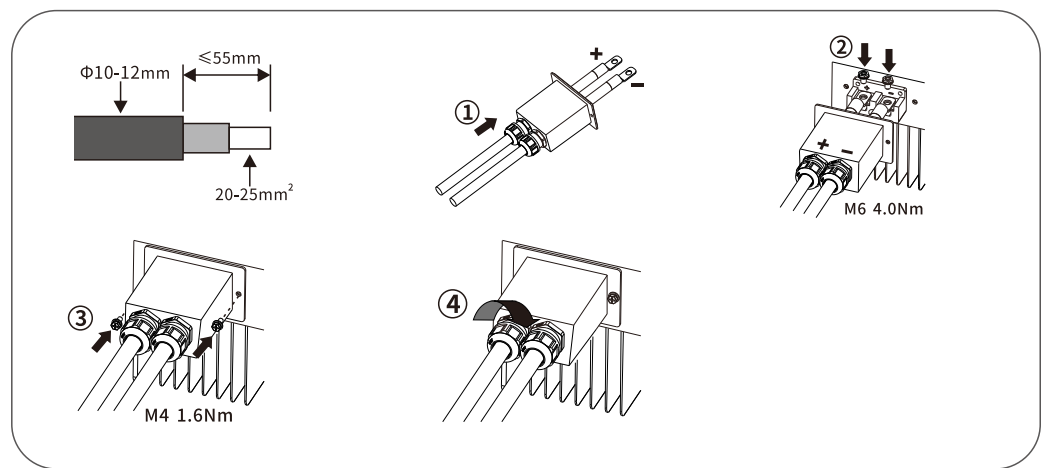

V. AC & EPS connection

- All electrical installations must be done in accordance with all local and national rules.
- Make sure that all DC switches and AC circuit breakers have been disconnected before establishing electrical connection. Otherwise, the high voltage within the inverter may lead to electrical shock.
- In accordance with safety regulations, the inverter need be grounded firmly. When poor ground connection (PE) occurs, the inverter will report PE grounding error. Please check and ensure that the inverter is grounded firmly or contact Hanchu ESS service.

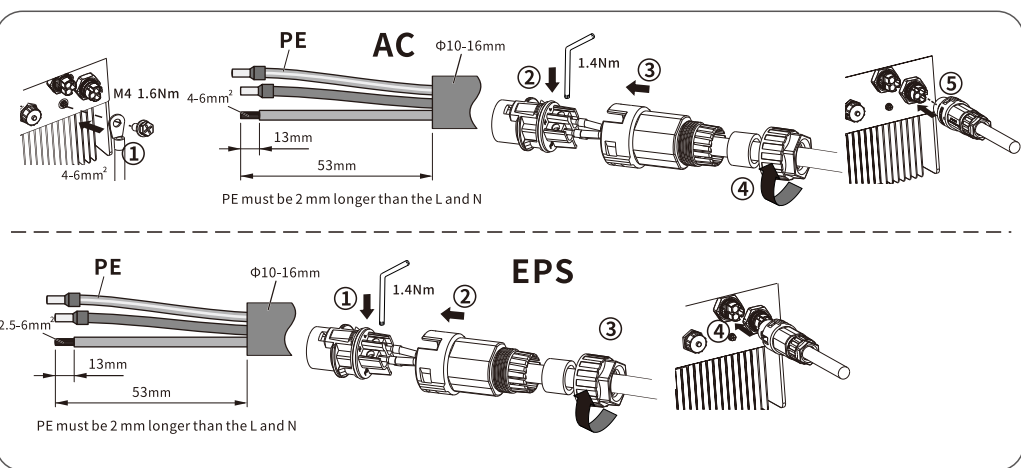

VII. DC connection

- Make sure PV modules have good insulation against ground.
- On the coldest day based on statistical records, the Max. open-circuit voltage of the PV modules must not exceed the Max. input voltage of the inverter.
- Check the polarity of DC cables.
- Ensure that DC switch has been disconnected.
- Do not disconnect DC connectors under load.

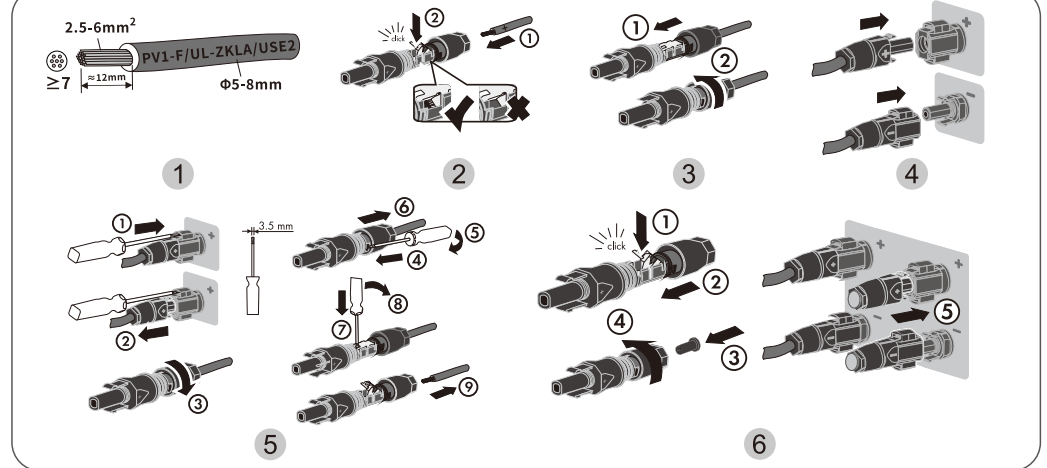

VIII. Smart meter connection

- DANGER** For outdoor use, the communication cables must be UV-resistant.
- Make sure AC cable is totally isolated from AC power before connecting.

SDM120CT(40mA) electric meter installation

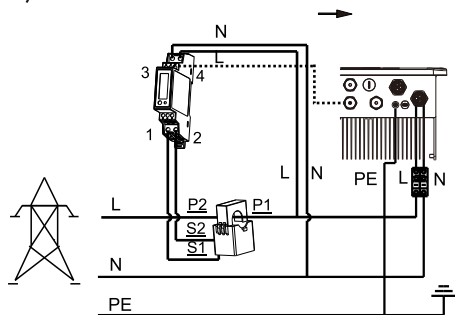

1. Smart meter communication

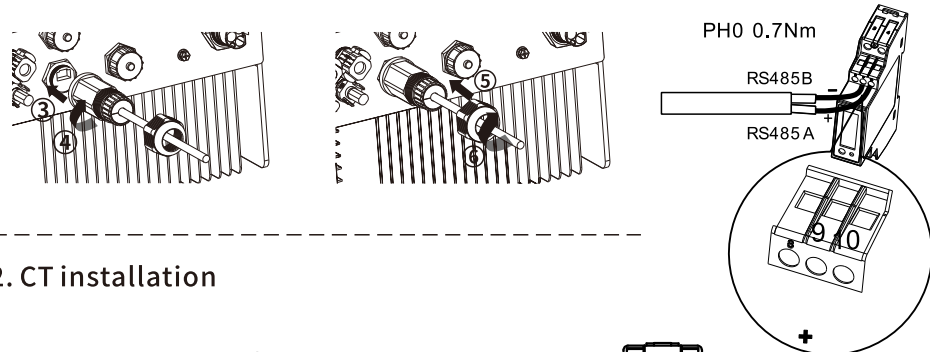
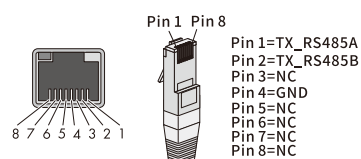

2. CT installation

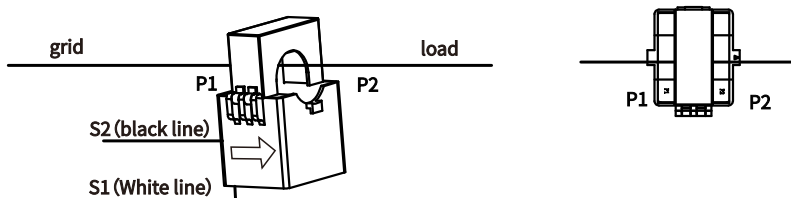

IX. Communication setup

- DANGER** Separate communication cables from power cables and serious interference sources.
- The communication cables must be CAT-5E or higher-level shield cables. Pin assignment complies with EIA/TIA 568B standard. For outdoor use, the communication cables must be UV-resistant. The total length of communication cable cannot exceed 1000m.

1. BMS communication

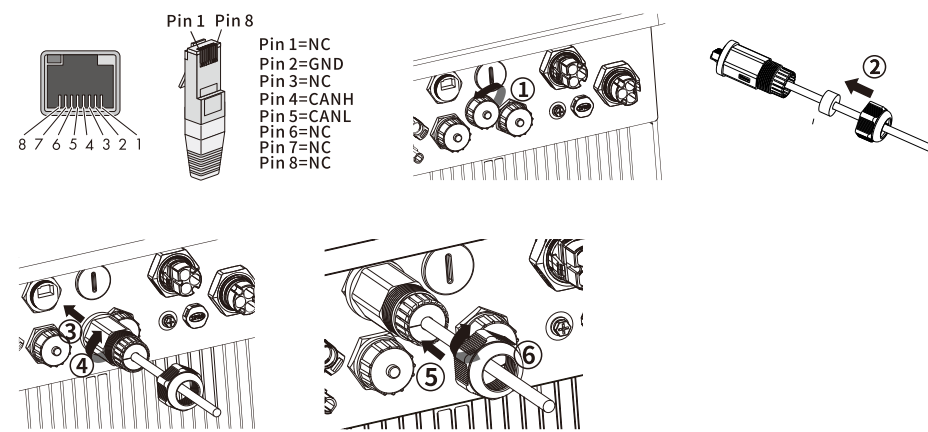

2. WiFi

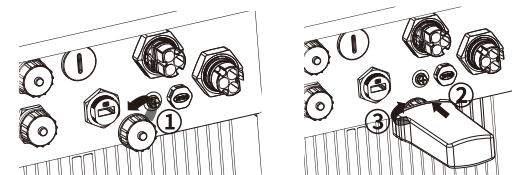

i The connection refers to "INV-Logger User Manual".

X. Commissioning

- Notice** Check that the inverter is grounded reliably.
- Check that the ventilation condition surrounding the inverter is good.
- Check that the grid voltage at the point of connection of the inverter is within the permitted range.
- Check that the sealing plugs in DC connectors and communication cable glands are sealed tightly.
- Check that grid/battery connection regulations and other parameter settings meet safety requirements.
- Check the correct communication connection between the battery BMS and the inverter.
- Check the correct communication connection between the smart meter and the inverter.

- Switch on AC circuit breaker between the inverter and the grid.
- Switch on DC switch.
- Switch on battery.
- Link to inverter WiFi.
- Set the communication parameters of the smart meter.
- Set parameters through App (Safety, Smart meter, Battery, Working-mode).
- Click power-on button through App, Energy storage inverter will start to work.

XI. EU Declaration of Conformity

- Within the scope of the EU directives:
- Electromagnetic compatibility 2014/30/EU (L 96/79-106, March 29, 2014)(EMC)
 - Low voltage directive 2014/35/EU (L 96/357-374, March 29, 2014)(LVD)
 - Radio equipment directive 2014/53/EU (L 153/62-106, May 22, 2014)(RED)



Jiangsu Hanchu Energy Technology Co.,LTD confirms herewith that the inverters mentioned in this document are in compliance with the fundamental requirements and other relevant provisions of the above mentioned directives.
The entire EU Declaration of Conformity can be found at www.hanchuess.com.

XII. Contact

If you have any technical problems with our products, please contact our service. We require the following information in order to provide you with the necessary assistance:

- Inverter device type
- Inverter serial number
- Battery type
- Type and number of connected PV modules
- Error code
- Mounting location
- Warranty card

Jiangsu Hanchu Energy Technology Co.,LTD
Hotline: +86 510 8887 6668
Web: www.hanchuess.com
Add.: No.588, Jinhui Road, Huishan District, Wuxi City, Jiangsu Province, China

